

Prénom : \_\_\_\_\_

Date : \_\_\_\_\_



# Géométrie

Reconnaître des formes simples  
dans une figure complexe

Colorie les formes géométriques de la couleur indiquée.

disque ⇒ rouge

rectangle ⇒ vert

triangle ⇒ bleu

autre ⇒ jaune

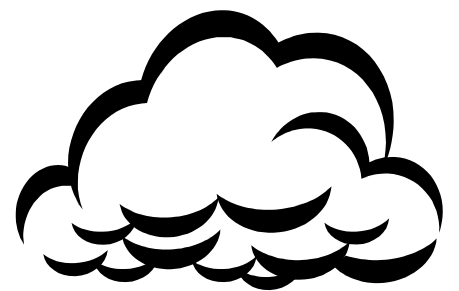
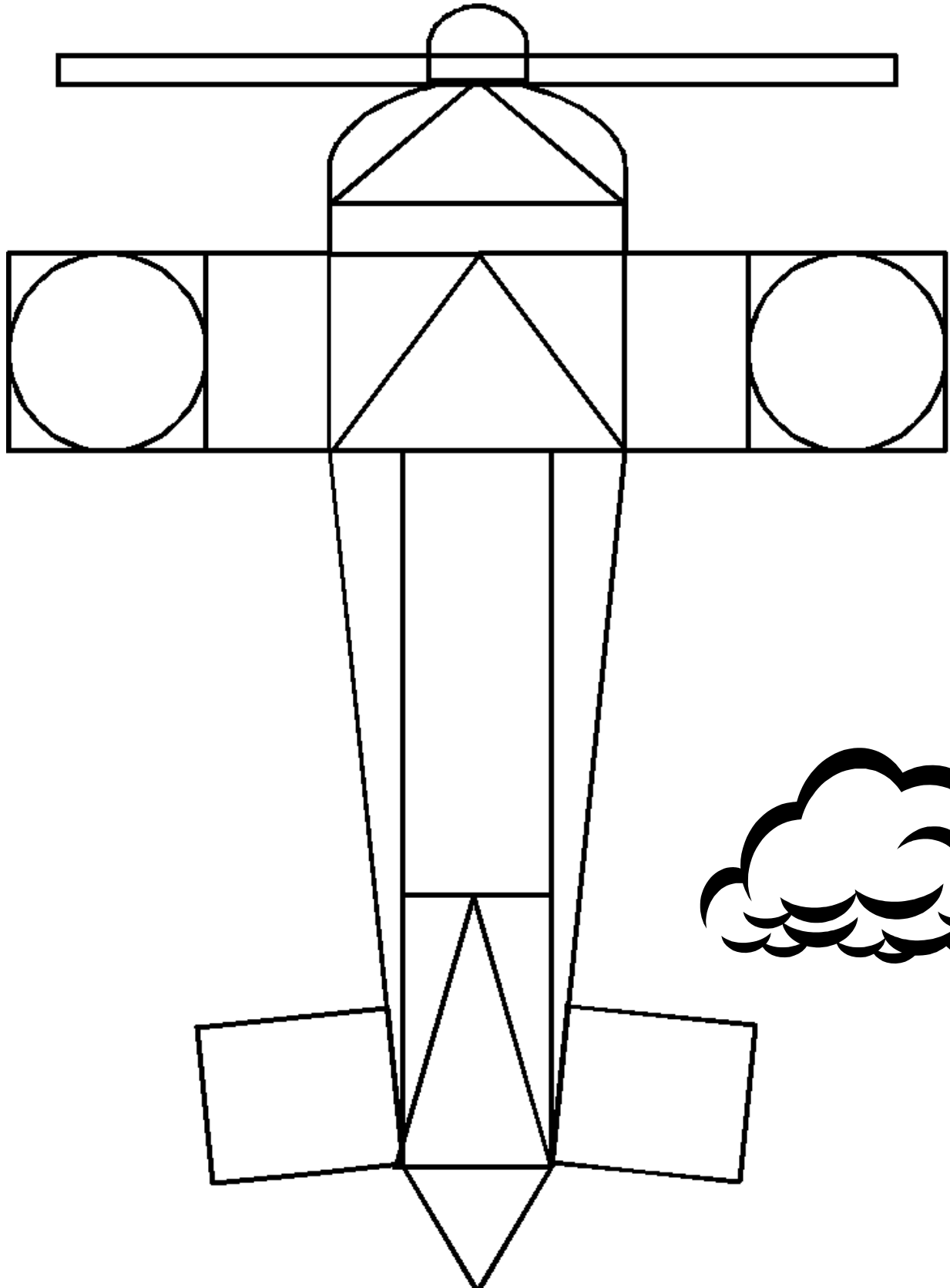

Prénom : \_\_\_\_\_

Date : \_\_\_\_\_



# Géométrie

Reconnaître des formes simples dans une figure complexe

Colorie les formes géométriques de la couleur indiquée.

disque ⇒ noir

rectangle ⇒ marron

triangle ⇒ orange

autre ⇒ jaune

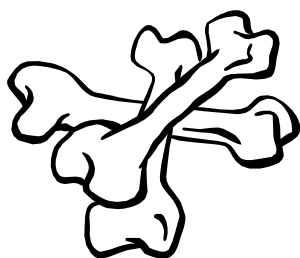
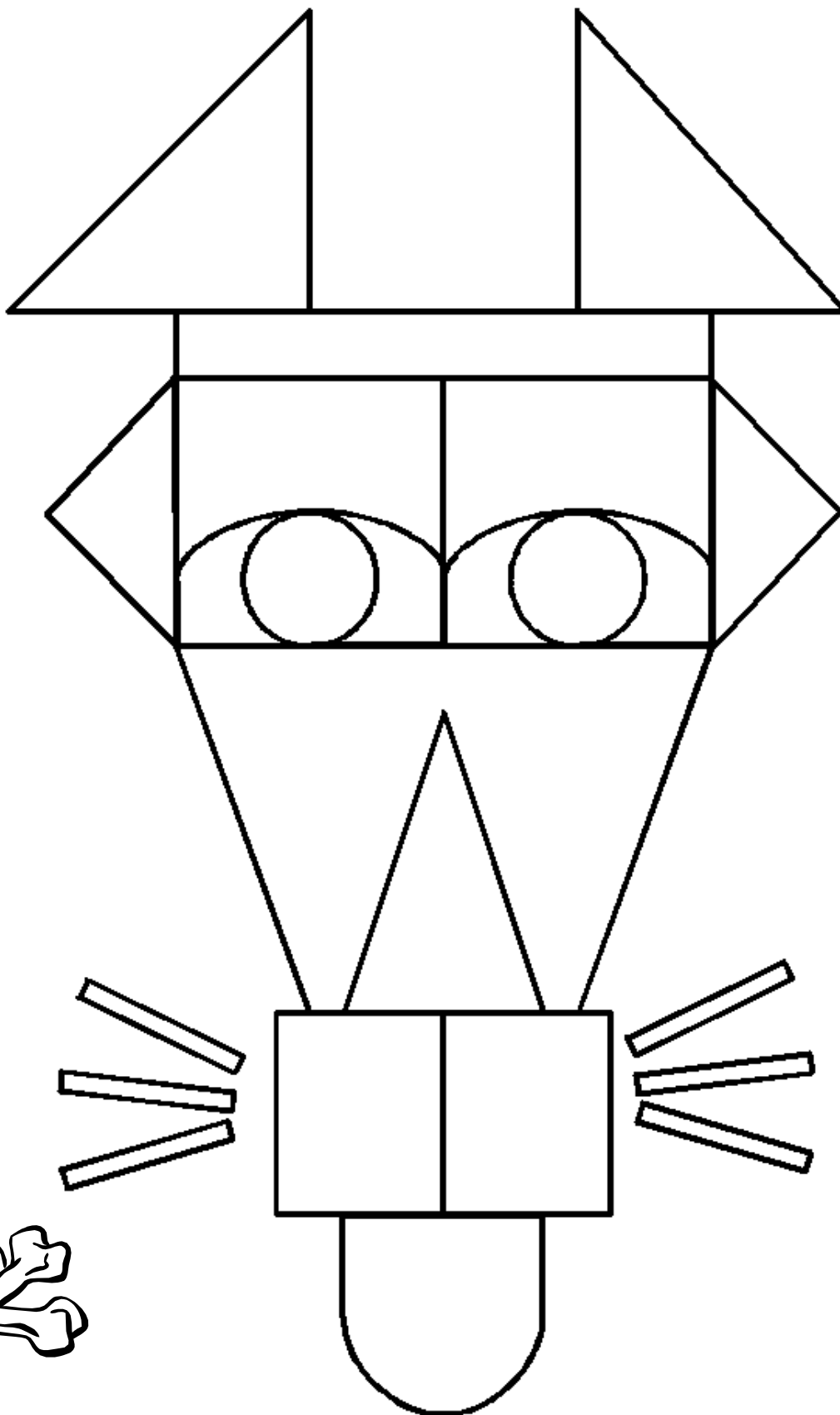

Prénom : \_\_\_\_\_

Date : \_\_\_\_\_



Coloriage magique

Somme de 2 nombres

Colorie en respectant le code couleur.

= 10

Jaune

= 11

Orange

= 12

Bleu

= 13

Vert

= 14

Noir

= 15

Marron

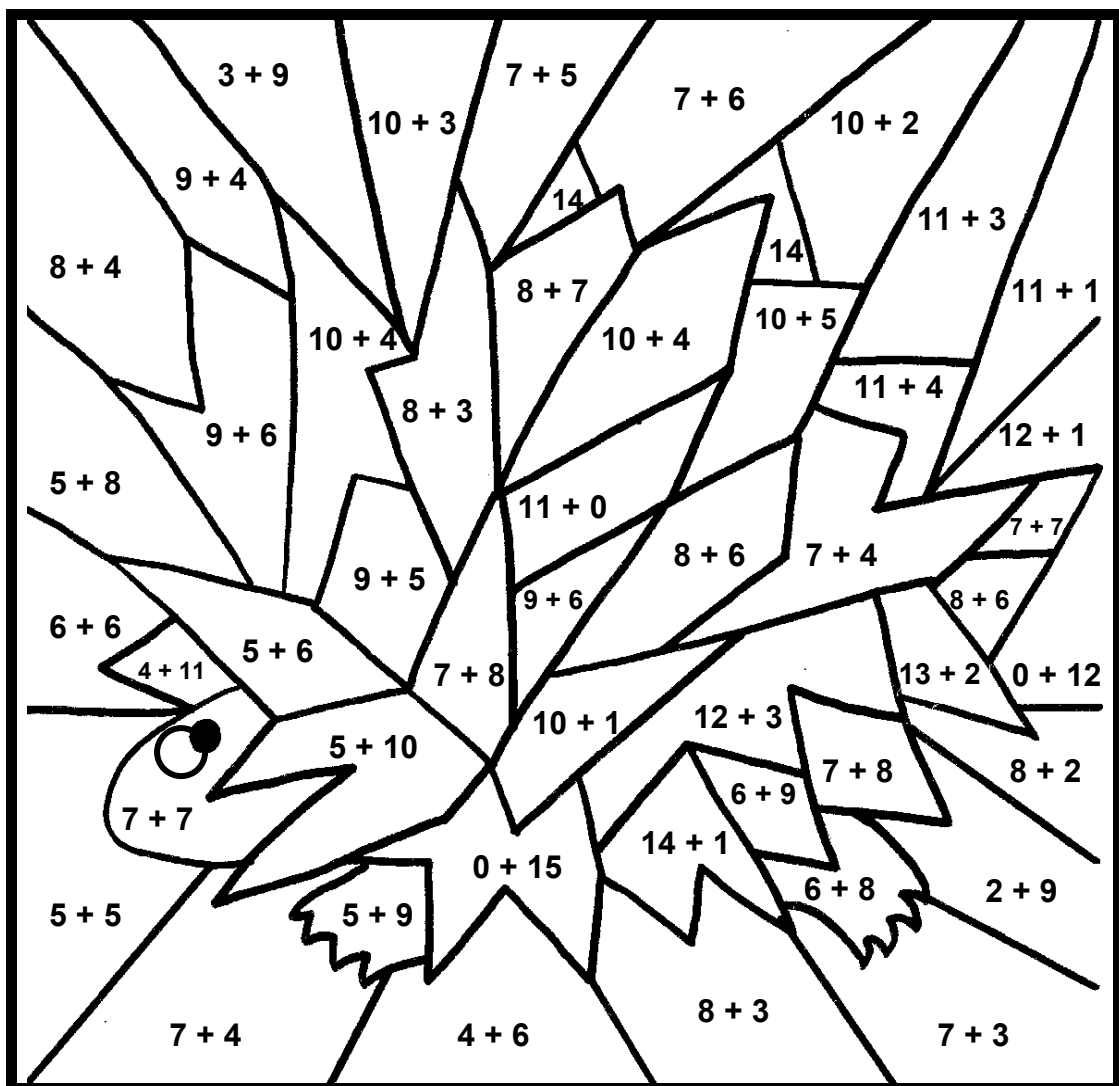

Prénom : \_\_\_\_\_

Date : \_\_\_\_\_

	<p>Utiliser les instruments géométriques Tracer à la règle.</p>	
---	---	--

Avec une règle et un crayon à papier, retrace la figure.

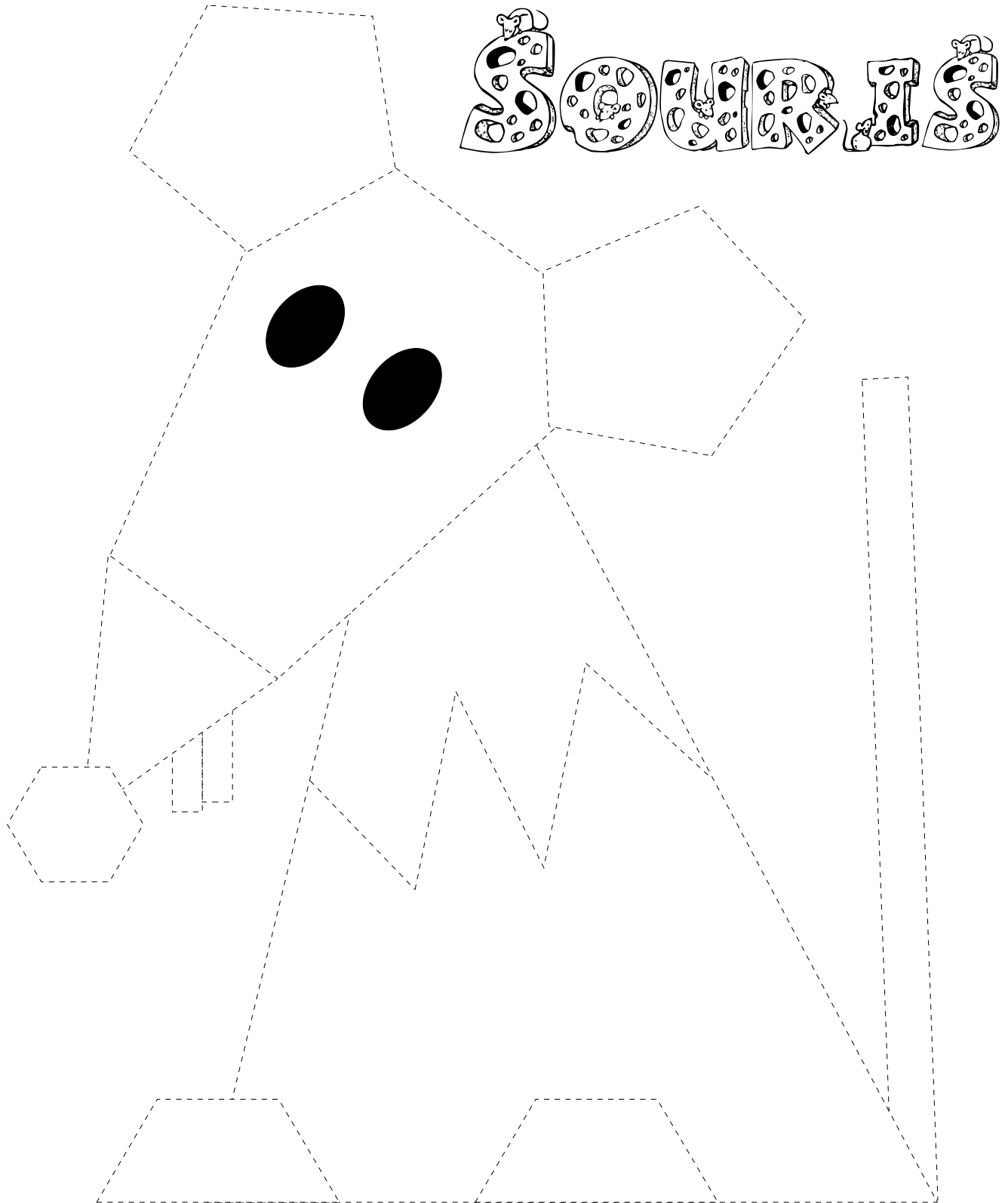

<http://lescoccinelles.free.fr>

Prénom : \_\_\_\_\_

Date : \_\_\_\_\_

	<p>Utiliser les instruments géométriques Tracer à la règle.</p>	
---	---	--

Avec une règle et un crayon à papier, retrace la figure.

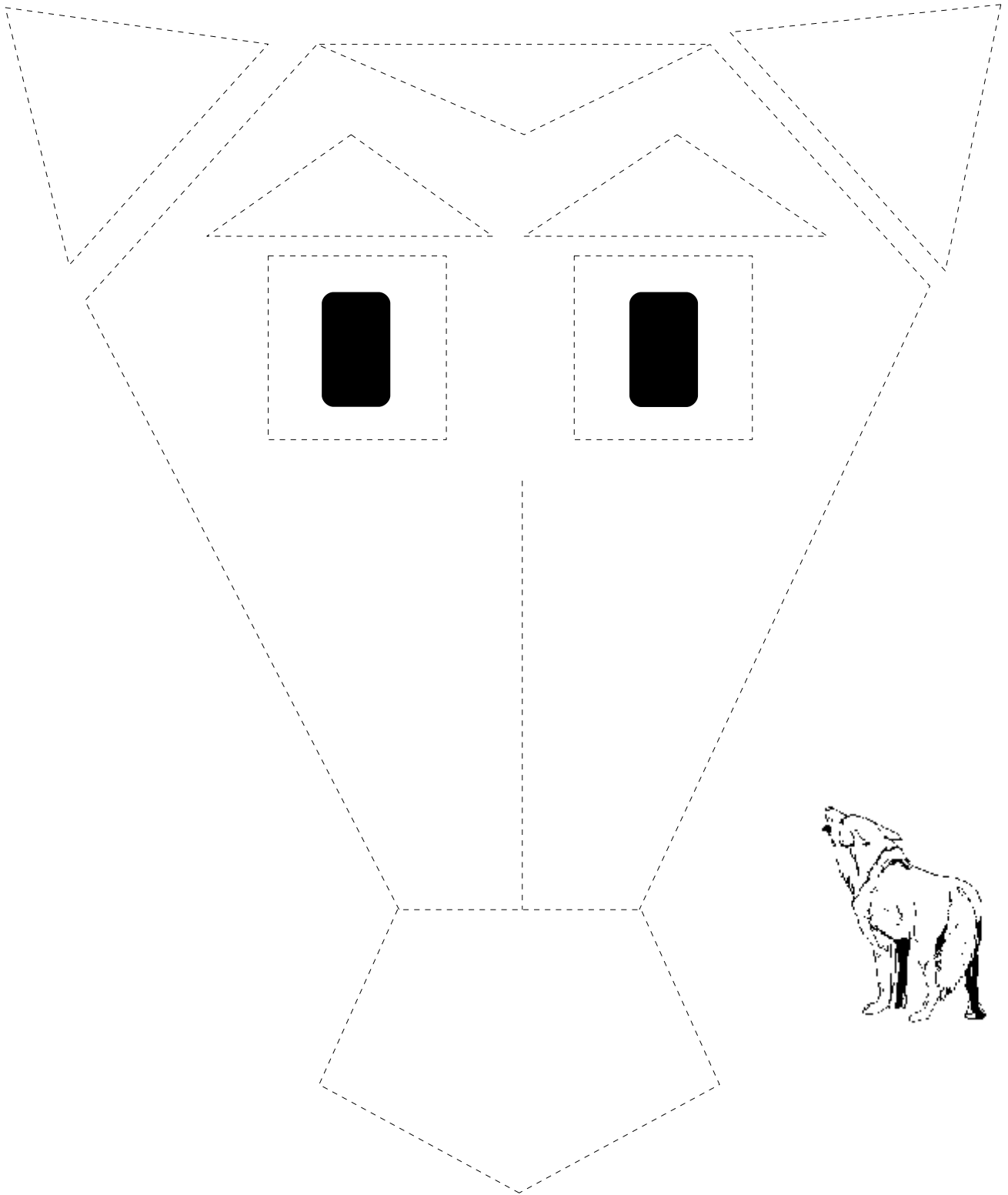

<http://lescoccinelles.free.fr>

Prénom : \_\_\_\_\_

Date : \_\_\_\_\_

	Utiliser les instruments géométriques	
	Tracer à la règle.	

Avec une règle et un crayon à papier, retrace la figure.



**GERONIMO**



## Les nombres de 0 à 69

- Complète la suite de nombres.

58 – 59 - \_\_\_\_ - \_\_\_\_ - \_\_\_\_ - \_\_\_\_ - \_\_\_\_ - \_\_\_\_ - \_\_\_\_ - \_\_\_\_ - \_\_\_\_ -

38 – 39 - \_\_\_\_ - \_\_\_\_ - \_\_\_\_ - \_\_\_\_ - \_\_\_\_ - \_\_\_\_ - \_\_\_\_ - \_\_\_\_ - \_\_\_\_ -

47 – 48 - \_\_\_\_ - \_\_\_\_ - \_\_\_\_ - \_\_\_\_ - \_\_\_\_ - \_\_\_\_ - \_\_\_\_ - \_\_\_\_ - \_\_\_\_ -

12 – 13 - \_\_\_\_ - \_\_\_\_ - \_\_\_\_ - \_\_\_\_ - \_\_\_\_ - \_\_\_\_ - \_\_\_\_ - \_\_\_\_ - \_\_\_\_ -

- Complète le tableau.

Avant	Nombre	Après
	68	
		70
65		
	64	
		61
		50

- Entoure les nombres qui sont **entre 53 et 63**

52      51      49      54      65      61      60      57

- Entoure les nombres qui sont **entre 32 et 48**

23      33      26      49      47      46      40      31

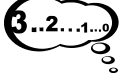

# Les nombres de 0 à 79

- Ecris sous chaque tableau le nombre.

d      u	d      u	d      u	d      u
<input style="width: 100%; height: 40px;" type="text"/>	<input style="width: 100%; height: 40px;" type="text"/>	<input style="width: 100%; height: 40px;" type="text"/>	<input style="width: 100%; height: 40px;" type="text"/>

- Complète avec  $>$  ou  $<$ .

65 \_\_\_ 75

26 \_\_\_ 62

75 \_\_\_ 57

36 \_\_\_ 73

64 \_\_\_ 74

76 \_\_\_ 67

72 \_\_\_ 62

26 \_\_\_ 62

74 \_\_\_ 47

- Range les nombres du plus petit au plus grand.

62 – 74 – 47 – 26 – 72 – 64

<  <  <  <  <  <

- Relie.

soixante-deux •

• 63

soixante-treize •

• 73

soixante-douze •

• 62

soixante-trois •

• 72



Prénom :

Date :



## Ecrire des mots

Objectif : trouver la lettre ou les lettres manquantes dans un mot.

✍ Complète chaque nom d'animal avec la ou les lettres manquantes.

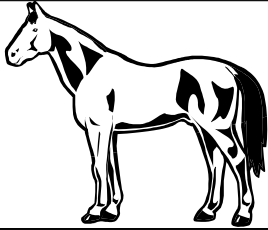

ch \_ v \_ l

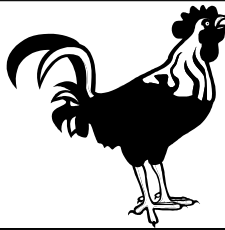

\_ o q

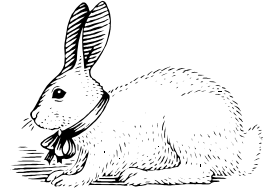

\_ a \_ in



\_ o r \_ u e



\_ e \_ p e n t



\_ a c h \_



\_ i n \_ o n

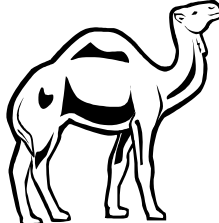

ch \_ m e a u



kan \_ o u \_ o u

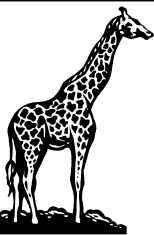

\_ i \_ a \_ e



\_ a n \_ a

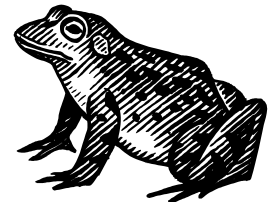

\_ r e \_ o u i l l \_

Prénom : \_\_\_\_\_

Date : \_\_\_\_\_



## Ecrire des mots

Objectif : écrire des mots « à syllabes simples »

 Ecris le mot qui correspond à l'image.

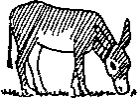

un \_\_\_\_\_



un \_\_\_\_\_



un \_\_\_\_\_



une \_\_\_\_\_



une \_\_\_\_\_

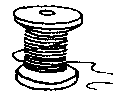

une \_\_\_\_\_



une \_\_\_\_\_



un \_\_\_\_\_



un \_\_\_\_\_



un \_\_\_\_\_



une \_\_\_\_\_



De la \_\_\_\_\_



un \_\_\_\_\_



un \_\_\_\_\_



un \_\_\_\_\_



une \_\_\_\_\_

Prénom : \_\_\_\_\_

Date : \_\_\_\_\_

 Identification des mots

Objectif : associer un mot écrit en cursif à une image.

Colorie le mot qui correspond à l'image.

	<i>carte</i>
	<i>cabine</i>
	<i>cadeau</i>
	<i>cadre</i>
	<i>cave</i>

	<i>chocolat</i>
	<i>coq</i>
	<i>coffre</i>
	<i>cochon</i>
	<i>confiture</i>

	<i>rouge</i>
	<i>route</i>
	<i>ronde</i>
	<i>rousse</i>
	<i>poule</i>

	<i>four</i>
	<i>foulard</i>
	<i>foudre</i>
	<i>fourmi</i>
	<i>fourchette</i>

	<i>fille</i>
	<i>ficelle</i>
	<i>filtre</i>
	<i>figue</i>
	<i>filet</i>

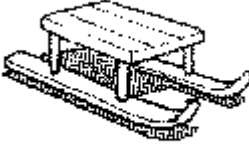
	<i>lune</i>
	<i>lutte</i>
	<i>luge</i>
	<i>lumière</i>
	<i>lutin</i>

	<i>roseau</i>
	<i>poisson</i>
	<i>ovale</i>
	<i>oiseau</i>
	<i>voiture</i>

	<i>sur</i>
	<i>mur</i>
	<i>dur</i>
	<i>pur</i>
	<i>mare</i>

Prénom :

Date :



## Lire des phrases

Objectif : associer le début et la fin d'une phrase.

↪ Relie le début à la fin pour reformer les phrases.

Le coiffeur ● ● prépare un rôti.

Le boucher ● ● fait cuire le pain.

Le boulanger ● ● coupe les cheveux.

Le garagiste ● ● apporte une lettre.

Le serveur ● ● répare la voiture.

Le facteur ● ● apporte le repas.

Prénom :

Date :



## Lire des phrases

Objectif : lire des phrases à mots « simples ».

↪ Lis les phrases et relie à l'image qui convient.

Le bûcheron coupe un arbre.

La sorcière vole sur un balai.

Il va à l'école.

Elle se lève.

Elle se douche.

Il peint un portrait.

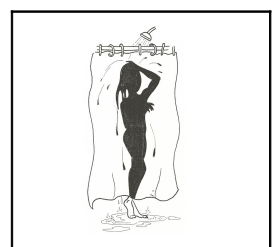
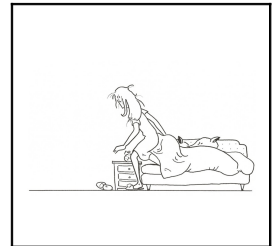

Prénom : \_\_\_\_\_

Date : \_\_\_\_\_



## Ecrire des phrases

Objectif : segmenter les mots dans une phrase.

 Sépare les mots d'un trait vertical et écris la phrase.

Exemple : *La voiture roule vite.*

⇒ *La voiture roule vite.*

1. *La motor roule vite.*

⇒ \_\_\_\_\_



2. *Papà répare la voiture.*

⇒ \_\_\_\_\_



3. *Elle porte un sac.*

⇒ \_\_\_\_\_



4. *Il mange une pomme.*

⇒ \_\_\_\_\_



5. *Il est malade.*

⇒ \_\_\_\_\_



Prénom : \_\_\_\_\_

Date : \_\_\_\_\_



LECTURE

Etude de sons

[wa]

Colorie lorsque tu entends le son [wa].

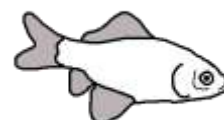
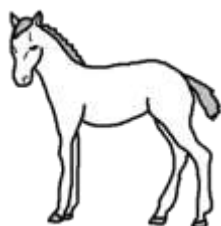
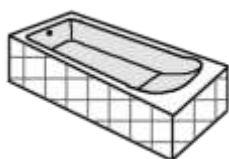
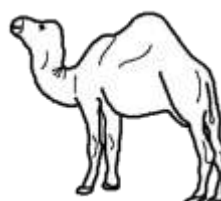
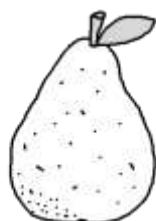
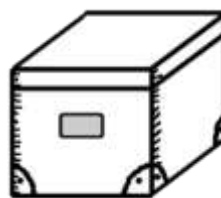
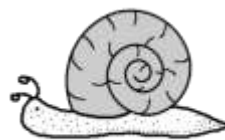

étoile – étoile



[wa]

oi oi

1. Entoure les lettres oi oi .

oi ai ou oi ui ou an ou ou oi on ou

on ai ou or ou oi on ou oi oi on ou

2. Entoure les lettres qui font le son [wa] dans chaque mot.

soir mouchoir boire poivre moi

couloir choisir foire TROIS

3. Relie chaque syllabe à une image.

coi

poi

voi

moi

roi







LECTURE

Mots fléchés

[wa]

oi

Complète la grille.

TROIS - COIFFEUSE - ROI - OISEAU - ARMOIRE - BAVOIR - BOITE - ROI - VOITURE - ETOILE - POIRE

The crossword grid is composed of empty squares. Illustrations and arrows indicate the starting points and directions for the words:

- Top:** An arrow points down to a single square, with a bird illustration to its right.
- Row 2:** An arrow points right to a horizontal row of 5 squares.
- Row 3:** An arrow points down to a single square, with a pear illustration to its right.
- Row 4:** An arrow points down to a single square, with a large number '3' and an arrow pointing down to a vertical column of 3 squares to its right.
- Row 5:** An arrow points right to a horizontal row of 5 squares, with a jar illustration to its left.
- Row 6:** An arrow points right to a horizontal row of 5 squares, with a car illustration to its left.
- Row 7:** An arrow points right to a horizontal row of 9 squares, with a hairdresser illustration to its left.
- Row 8:** An arrow points right to a horizontal row of 6 squares, with a star illustration to its left.
- Row 9:** An arrow points right to a horizontal row of 7 squares, with a wardrobe illustration to its left and a king's head illustration to its right.
- Row 10:** An arrow points right to a horizontal row of 5 squares, with a box illustration to its left.



LECTURE

Assemblage syllabique

Sac à syllabes

Forme dix mots avec les syllabes contenues dans le sac.

### Les vêtements



1.

2.

3.

4.

5.

6.

7.

8.

9.

10.